

REVISIONS				
ZONE	REV.	DESCRIPTION	DATE	APPROVED

SPECIFICATION:

CAPACITY	110KW 3-PHASE, 73KW 1-PHASE, 5KW RESOLUTION STANDARD
LOAD TYPE	RESISTIVE
POWER FACTOR	1.0
VOLTAGES	240/480V 3-PHASE, 240V 1-PHASE
FREQUENCY	50/60HZ
FULL LOAD AMPS	240V 3-PHASE: 256A, 480V 3-PHASE: 132A, 240V 1-PHASE: 294A
COOLING SYSTEM	FORCED AIR, AIR FLOW 2400CFM (UNRESTRICTED), DIRECTION HORIZONTAL
TEMPERATURE RATING	MAXIMUM AIR INTAKE TEMPERATURE 125°F, MAXIMUM EXHAUST TEMPERATURE 600°F
FAN/CONTROL POWER	EXTERNAL 120VAC 1-PHASE 60HZ 10A POWER SOURCE, CORD WITH PLUG PROVIDED
DIMENSIONS (MAXIMUM)	26"W x 35"H x 21"D
APPROX WEIGHT	198.50LBS / 90KG FOR ALUMINUM FABRICATION (EXCLUDING HAND HELD CONTROL CONSOLE)
FINISH	UL POWDER COATED, COLOR: RAL-7042 TRAFFIC GREY A

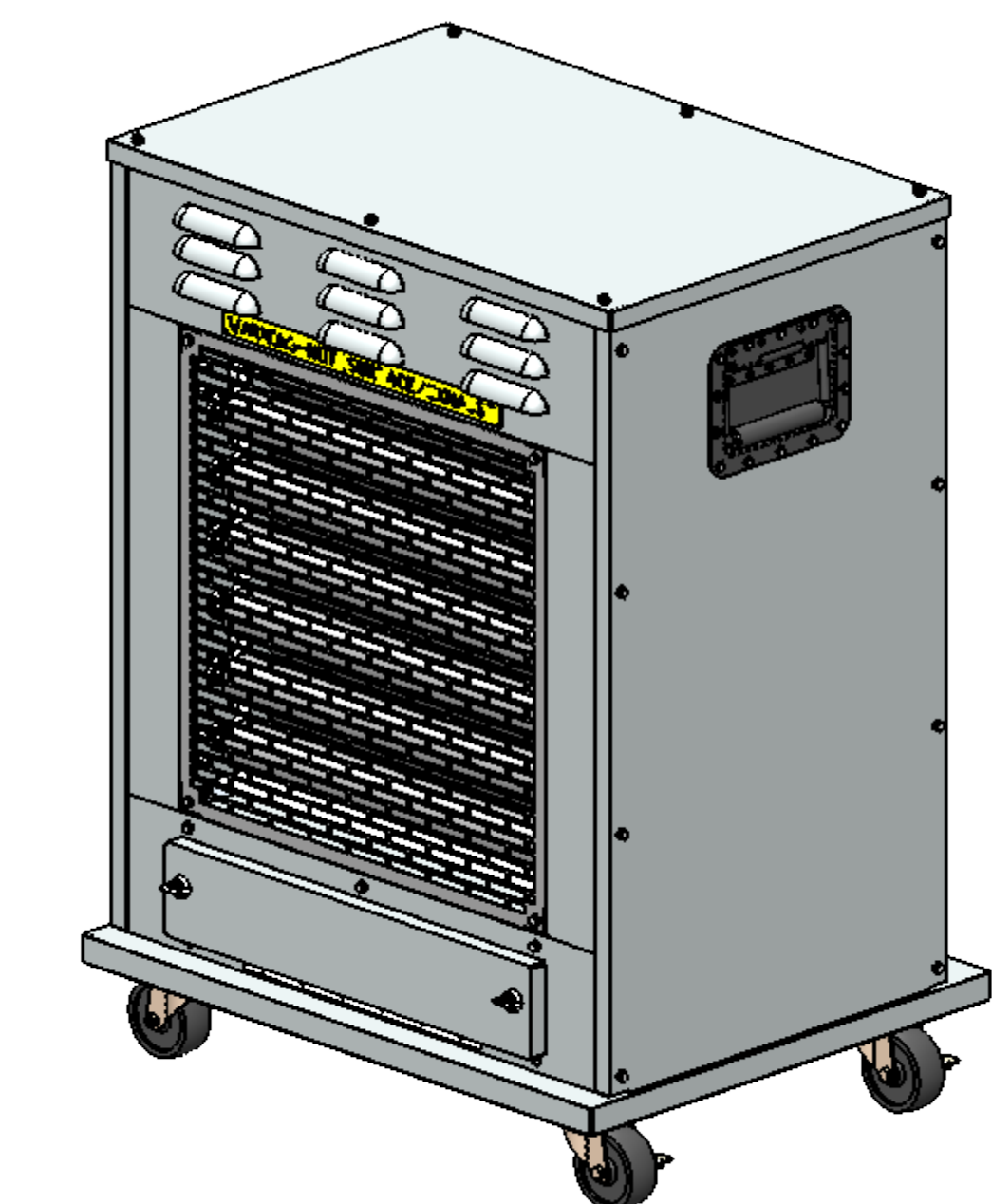
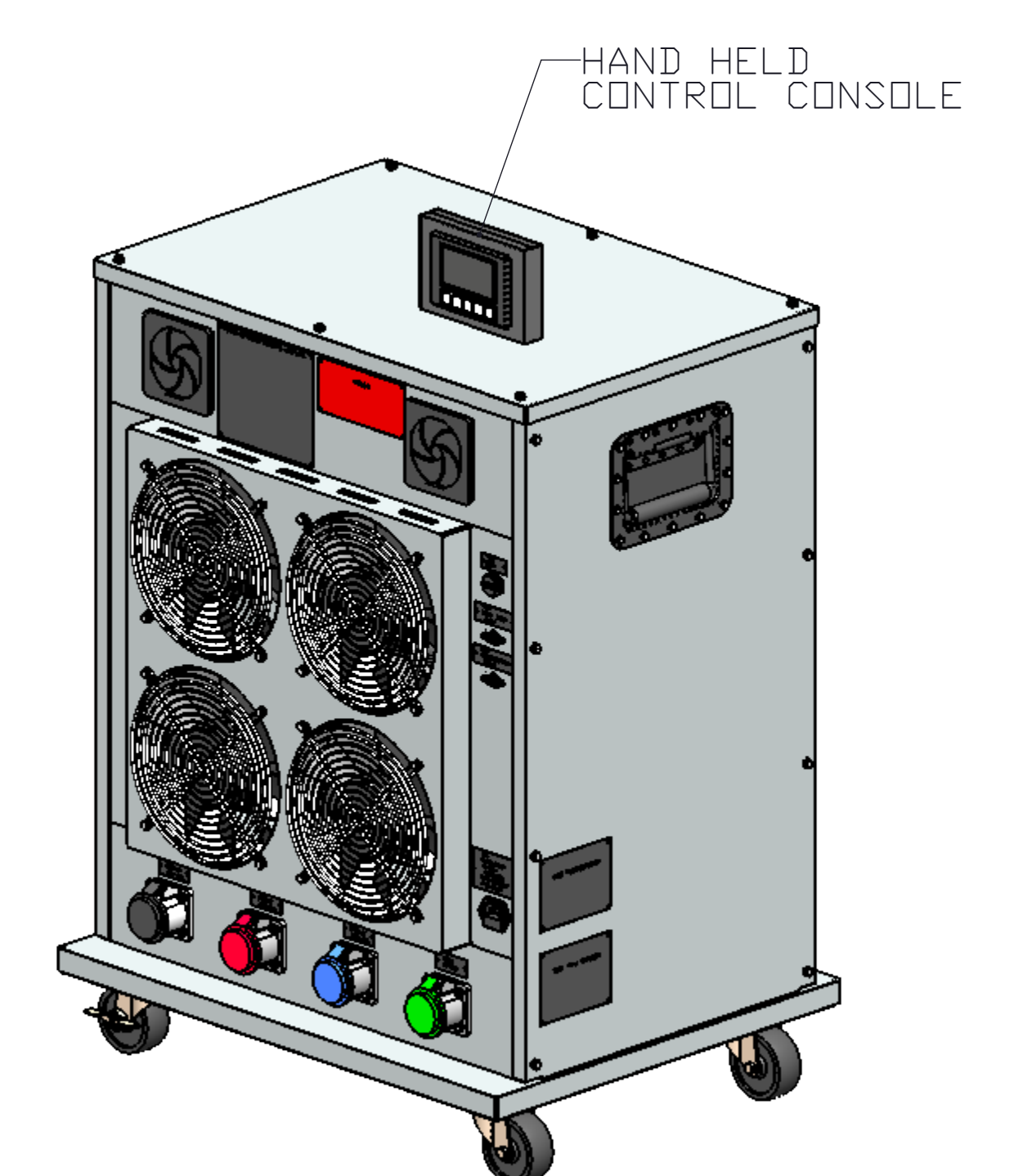
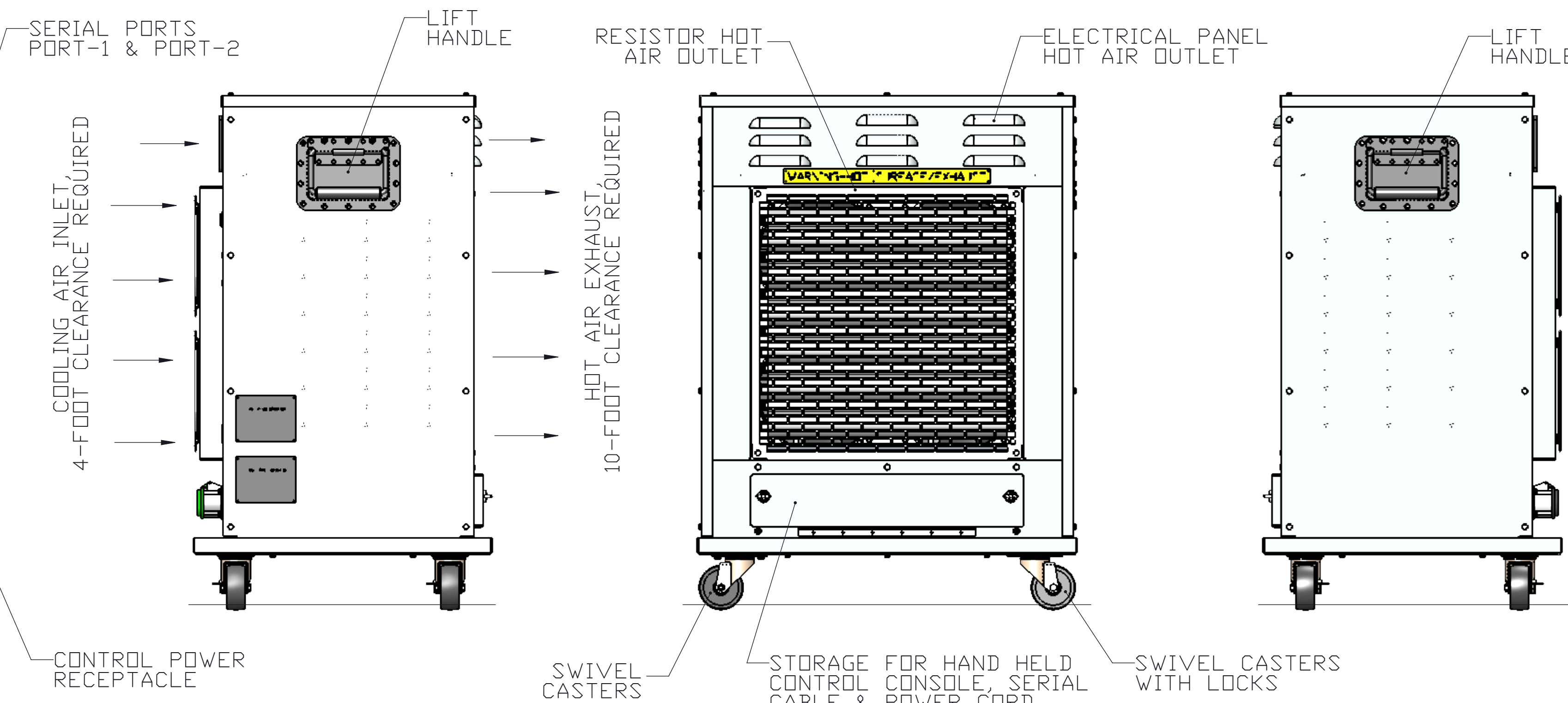
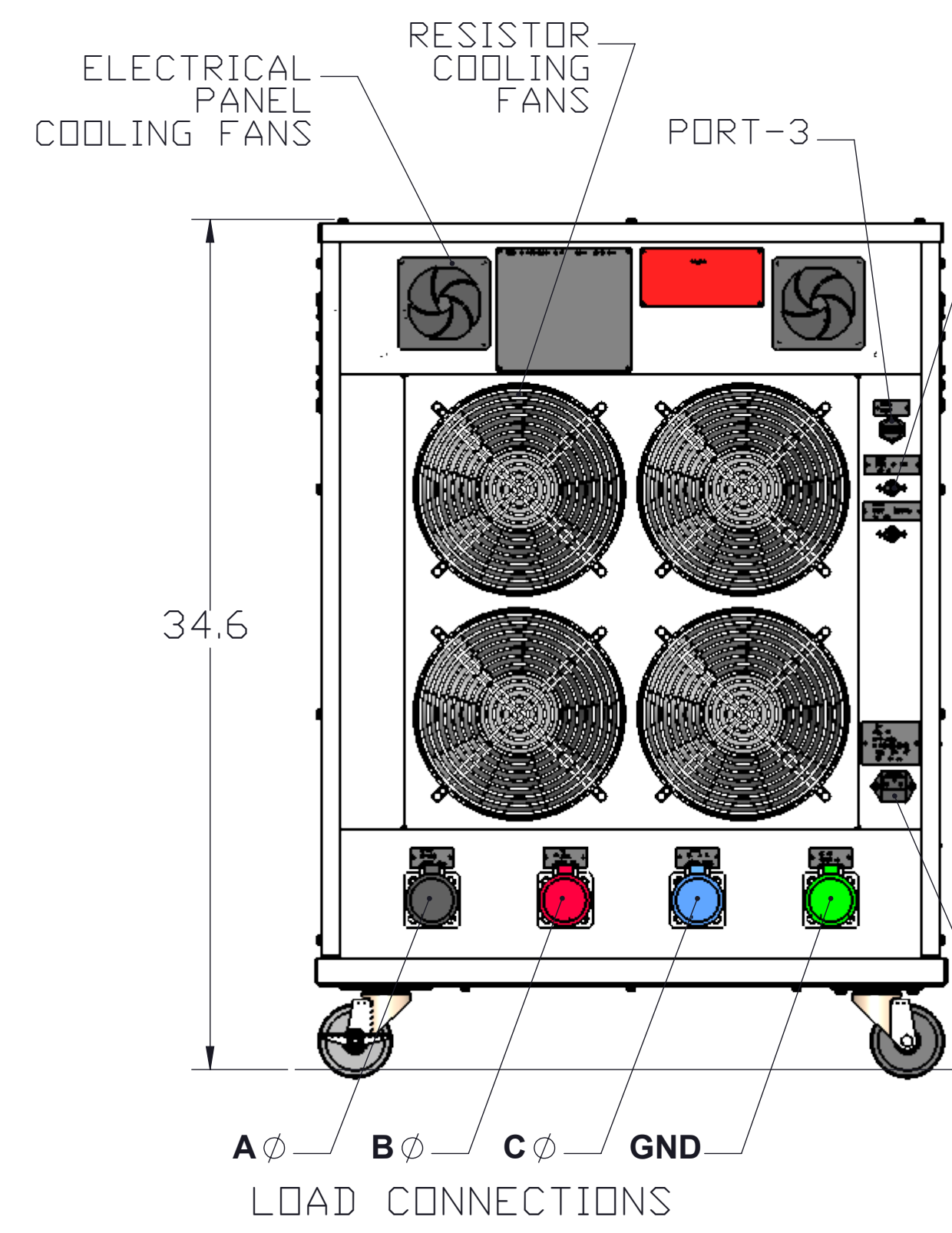
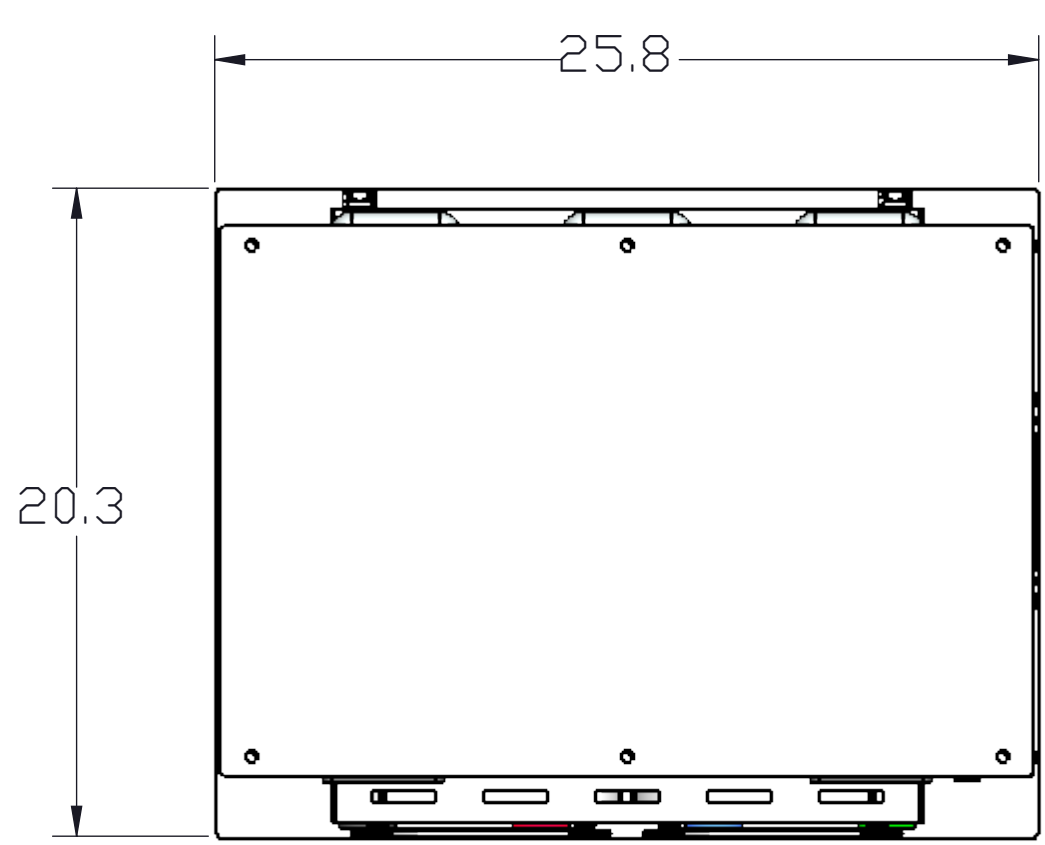

DESCRIPTION:

ULB-R110-240-480-IP IS MODERN RESISTIVE LOAD BANK SYSTEM INTENDED FOR FIELD USE IN TESTING AND MAINTENANCE EXERCISE OF GENERATORS, UPS AND OTHER AC POWER SOURCES. ULB-R110 SERIES PORTABLE LOAD BANKS ARE DESIGNED FOR INDOOR USE, CONFIGURABLE FOR 5-110 KW RANGE, DIGITALLY CONTROLLED VIA AN ON-BOARD HAND HELD CONTROL CONSOLE, CAPABLE OF DATA MONITORING AND DATA ACQUISITION, AND CAN BE OPERATED IN MANUAL, AUTOMATIC OR MULTI-STATION MODE

MODEL NUMBER CODE REFERENCE TABLE:

- ULB - UNIVERSAL LOAD BANK
- R - RESISTIVE
- 110 - MAXIMUM CAPACITY 110 KW
- 240 - NOMINAL VOLTAGE 240 VAC
- 480 - NOMINAL VOLTAGE 480 VAC
- - OPTION: FOR OUTDOOR USE
- I - OPTION: FOR INDOOR USE ONLY
- S - OPTION: STATIONARY
- P - OPTION: PORTABLE ON CASTERS
- T - OPTION: PORTABLE ON TRAILER
- A,B,C - ELECTRICAL CONFIGURATION (60, 54 & 48 RESISTORS CORRESPONDINGLY)

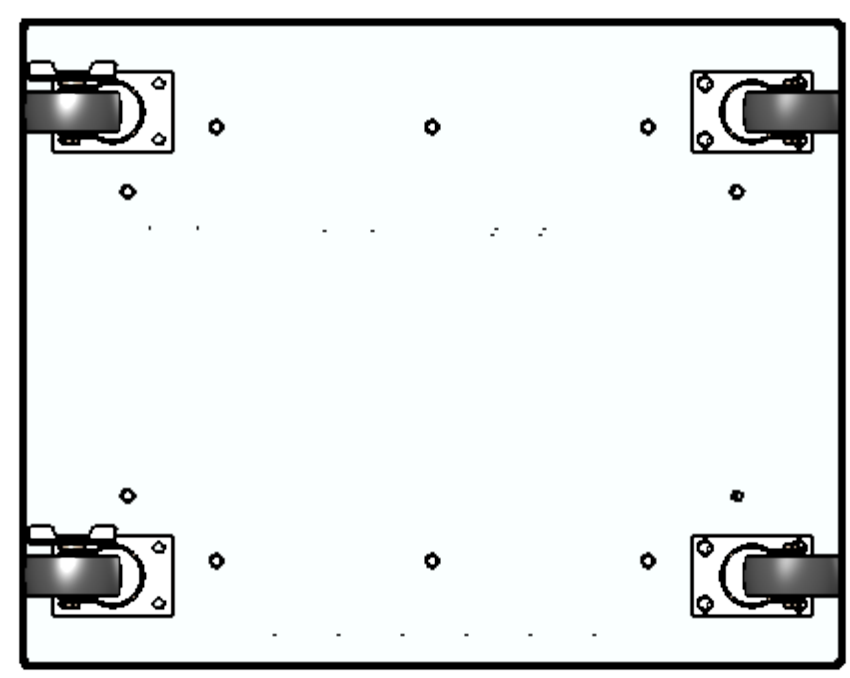

FINISH RAL 7042 POWDER COATED	MATERIAL ALUMINUM 2.5MM THK	UNLESS OTHERWISE SPECIFIED DIMENSIONS ARE IN INCHES TOLERANCES:FRACTIONS: ± 1/8 ANGLES: ± 0° 30' 2 PLACE DECIMALS: ± .03 3 PLACE DECIMALS: ± .010	APPROVALS DRAWN: JP CHECKED: KP ENGR: KP QUAL: REL:	DATE	
<p>CONFIDENTIAL/PROPRIETARY</p> <p>THIS DOCUMENT CONTAINS THE CONFIDENTIAL AND PROPRIETARY INFORMATION OF ULB. YOU MAY NOT POSSESS, USE, COPY OR DISCLOSE THIS DOCUMENT OR ANY INFORMATION IN IT FOR ANY PURPOSE WITHOUT EXPRESS WRITTEN PERMISSION. NEITHER RECEIPT, FROM ANY SOURCE, NOR POSSESSION OF THIS DOCUMENT, CONSTITUTES SUCH PERMISSION. POSSESSION, USE, COPYING OR DISCLOSURE BY ANYONE WITHOUT EXPRESS WRITTEN PERMISSION OF ULB IS NOT AUTHORIZED AND MAY RESULT IN CRIMINAL AND/OR CIVIL LIABILITY.</p>			CONTRACT NUMBER JOB#1143	SCALE D	
			DO NOT SCALE DRAWING	WEIGHT: 1	SHEET: 1 of 1