

CAPACITY	310KW 3-PHASE, 168KW 1-PHASE, 5KW RESOLUTION STANDARD
LOAD TYPE	RESISTIVE
POWER FACTOR	1.0
VOLTAGES	240/480V 3-PHASE, 240V 1-PHASE
FREQUENCY	50/60HZ
FULL LOAD AMPS	240V 3-PHASE: 700A, 480V 3-PHASE: 373A, 240V 1-PHASE: 700A,
COOLING SYSTEM	FORCED AIR, AIR FLOW - 6600 CFM (UNRESTRICTED), DIRECTION HORIZONTAL
TEMPERATURE RATING	MAXIMUM AIR INTAKE TEMPERATURE 125°F, MAXIMUM EXHAUST TEMPERATURE 600°F
FAN/CONTROL POWER	EXTERNAL 120VAC 1-PHASE 50/60HZ 10A POWER SOURCE. CORD WITH PLUG PROVIDED
DIMENSIONS (MAXIMUM)	30"W x 58"H x 25"D
APPROX WEIGHT	375 LBS / 170KG (EXCLUDING HAND HELD CONTROL CONSOLE)
FINISH	UL POWDER COATED.

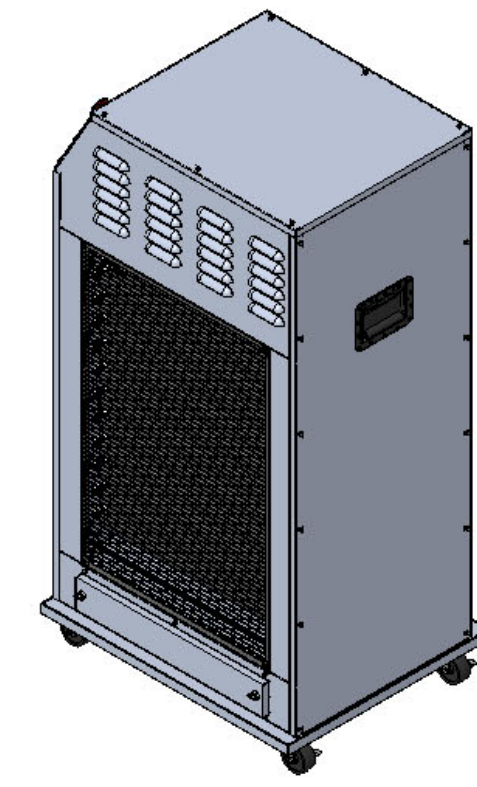

MODEL NUMBER CODE REFERENCE TABLE:

- ULB - UNIVERSAL LOAD BANK.
- R - RESISTIVE
- 310 - MAXIMUM CAPACITY 310 KW
- 240 - NOMINAL VOLTAGE 240 VAC
- 480 - NOMINAL VOLTAGE 480 VAC
- - OPTION : FOR OUTDOOR USE
- I - OPTION : FOR INDOOR USE ONLY
- S - OPTION : STATIONARY
- P - OPTION : PORTABLE ON CASTERS
- T - OPTION : PORTABLE ON TRAILER
- UR - UNITED RENTAL

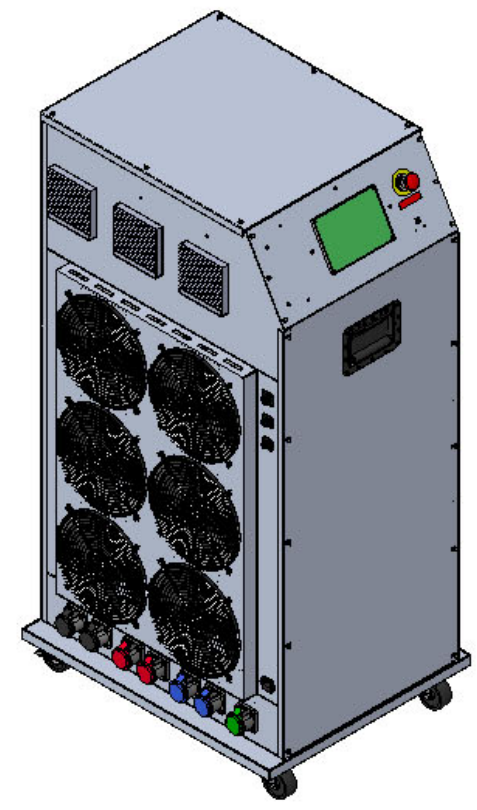
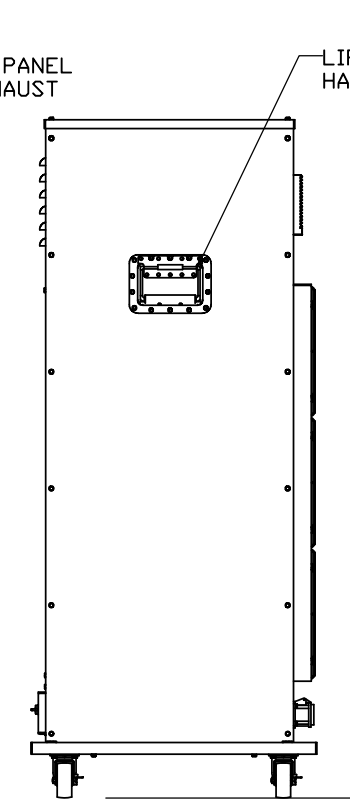
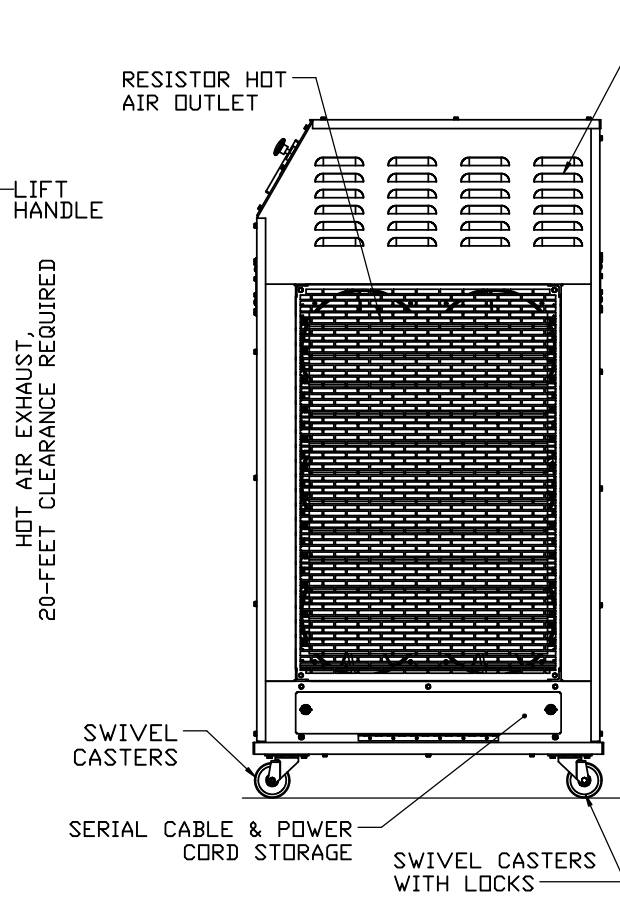
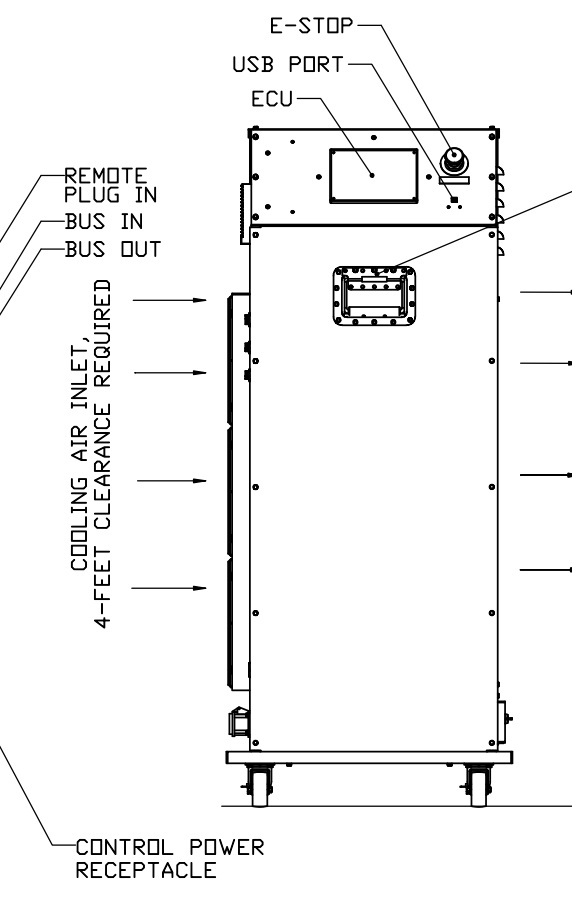
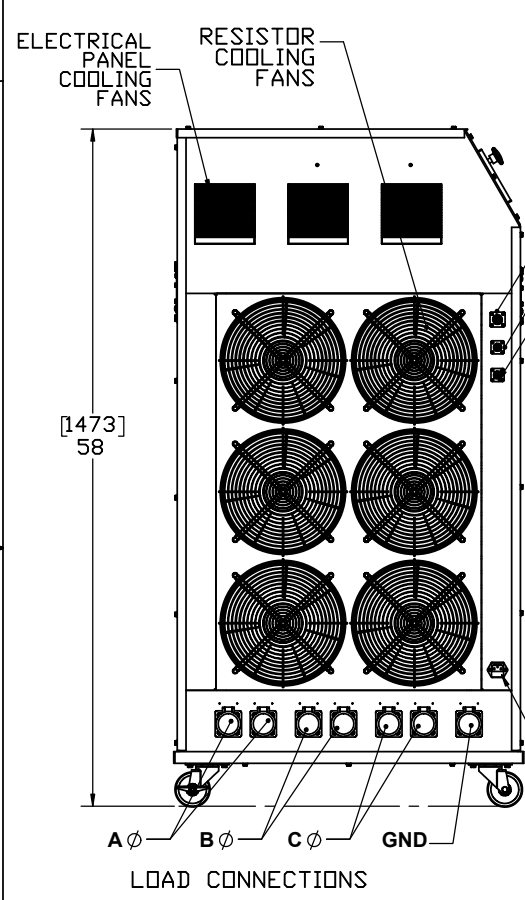
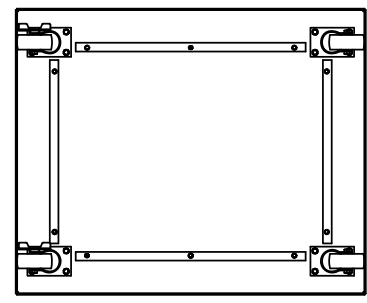

FINISH POWDER COATED RAL 5005/RAL6037 &RAL 7042	MATERIAL ALUMINUM 2.5MM THK	UNLESS OTHERWISE SPECIFIED DIMENSIONS ARE IN INCHES TOLERANCES:FRACTIONS ± 1/8 ANGLES ± 0° 30' 2 PLACE DECIMALS ± .03 3 PLACE DECIMALS ± .010	APPROVALS DRAWN N.D.R. CHECKED ENGR. QUAL. REL.	DATE 01/09/22	
CONFIDENTIAL/PROPRIETARY			CONTRACT NUMBER JOB#1215		
THIS DOCUMENT CONTAINS THE CONFIDENTIAL AND PROPRIETARY INFORMATION OF ULB. YOU MAY NOT POSSESS, USE, COPY OR DISCLOSE THIS DOCUMENT OR ANY INFORMATION IN IT FOR ANY PURPOSE WITHOUT EXPRESS WRITTEN PERMISSION. NEITHER RECEIPT, FROM ANY SOURCE, NOR POSSESSION OF THIS DOCUMENT, CONSTITUTES SUCH PERMISSION. POSSESSION, USE, COPYING OR DISCLOSURE BY ANYONE WITHOUT EXPRESS WRITTEN PERMISSION OF ULB IS NOT AUTHORIZED AND MAY RESULT IN CRIMINAL AND/OR CIVIL LIABILITY.			DO NOT SCALE DRAWING		SIZE D
			CAGE CODE 8LKM0		A102601-P0
			SCALE -	WEIGHT: XXXX	SHEET: 1 of 1

11/01/2023

A