

REVISIONS				
ZONE	REV.	DESCRIPTION	DATE	APPROVED

SPECIFICATION:

CAPACITY	3000KW, RESISTIVE, 1.0 POWER FACTOR
VOLTAGE	480 VAC
FREQUENCY	60HZ
LOAD STEPS	25KW RESOLUTION STANDARD
DUTY CYCLE	CONTINUOUS
MAX. AMBIENT TEMPERATURE	120 F
MAX EXHAUST TEMP. RIZE	150-200 F, HDT SPOTS 550 F
AIR FLOW	3X20000CFM, 10HP/EACH
FAN/CONTROL VOLTAGE	FAN OPERATES AT 3-PHASE LINE VOLTAGE, LOAD AND MOTOR CONTROL CIRCUITS OPERATE AT 120V VIA INTERNAL TRANSFORMER
APPROX WEIGHT	7200LBS / 3266KG

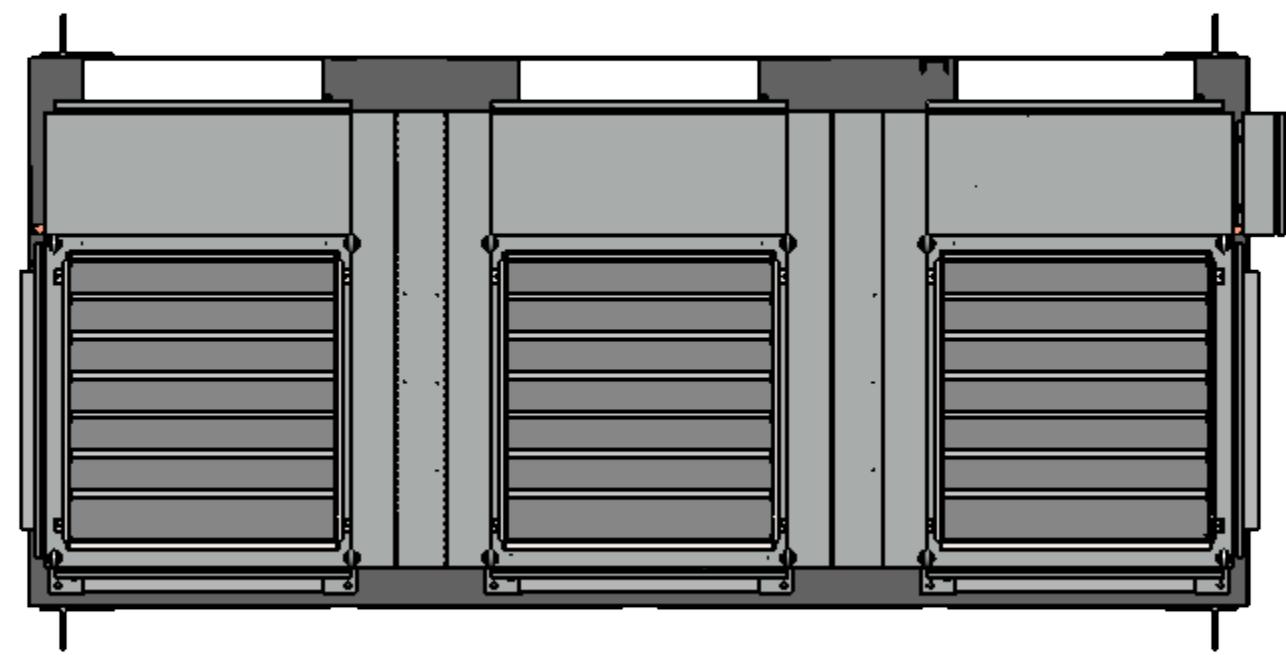

TOP VIEW

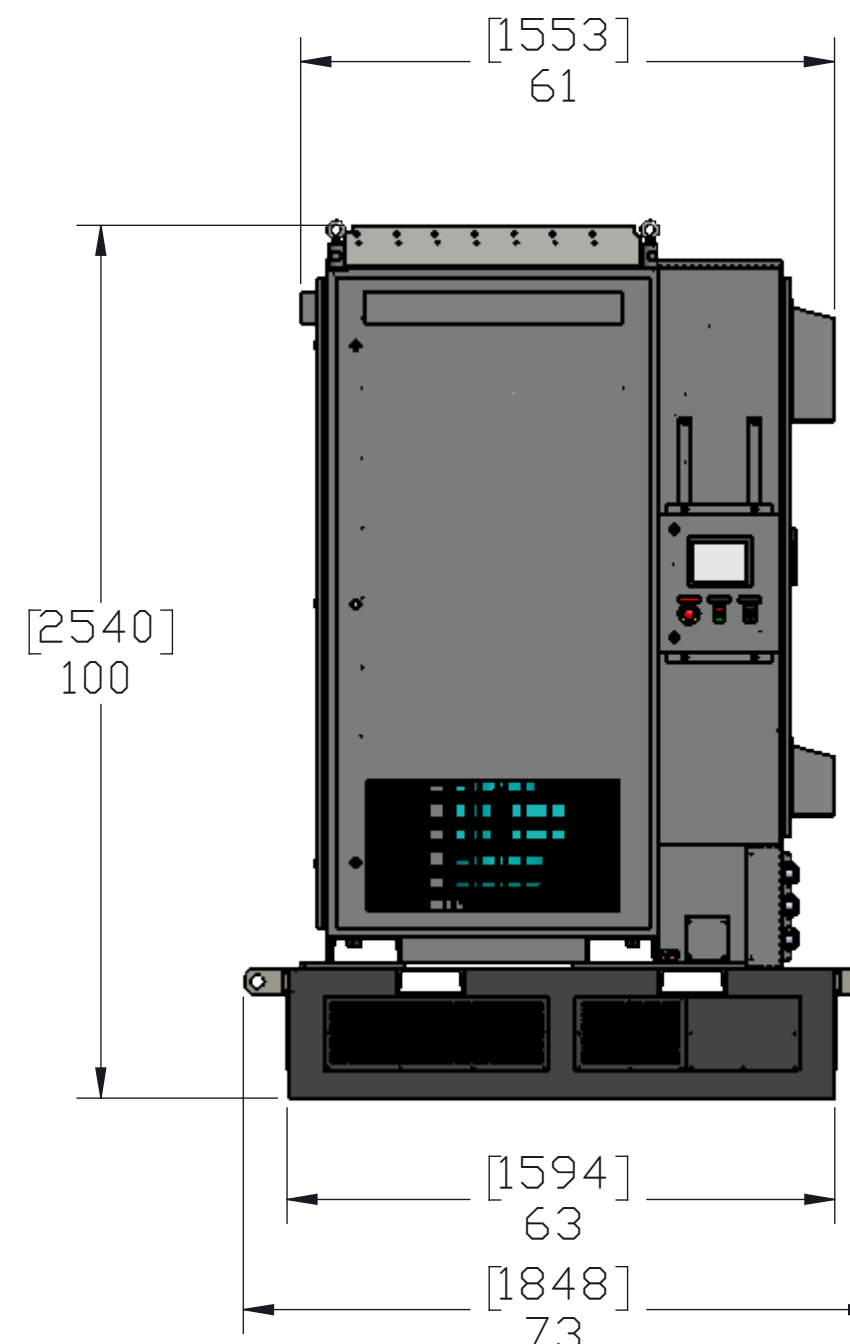
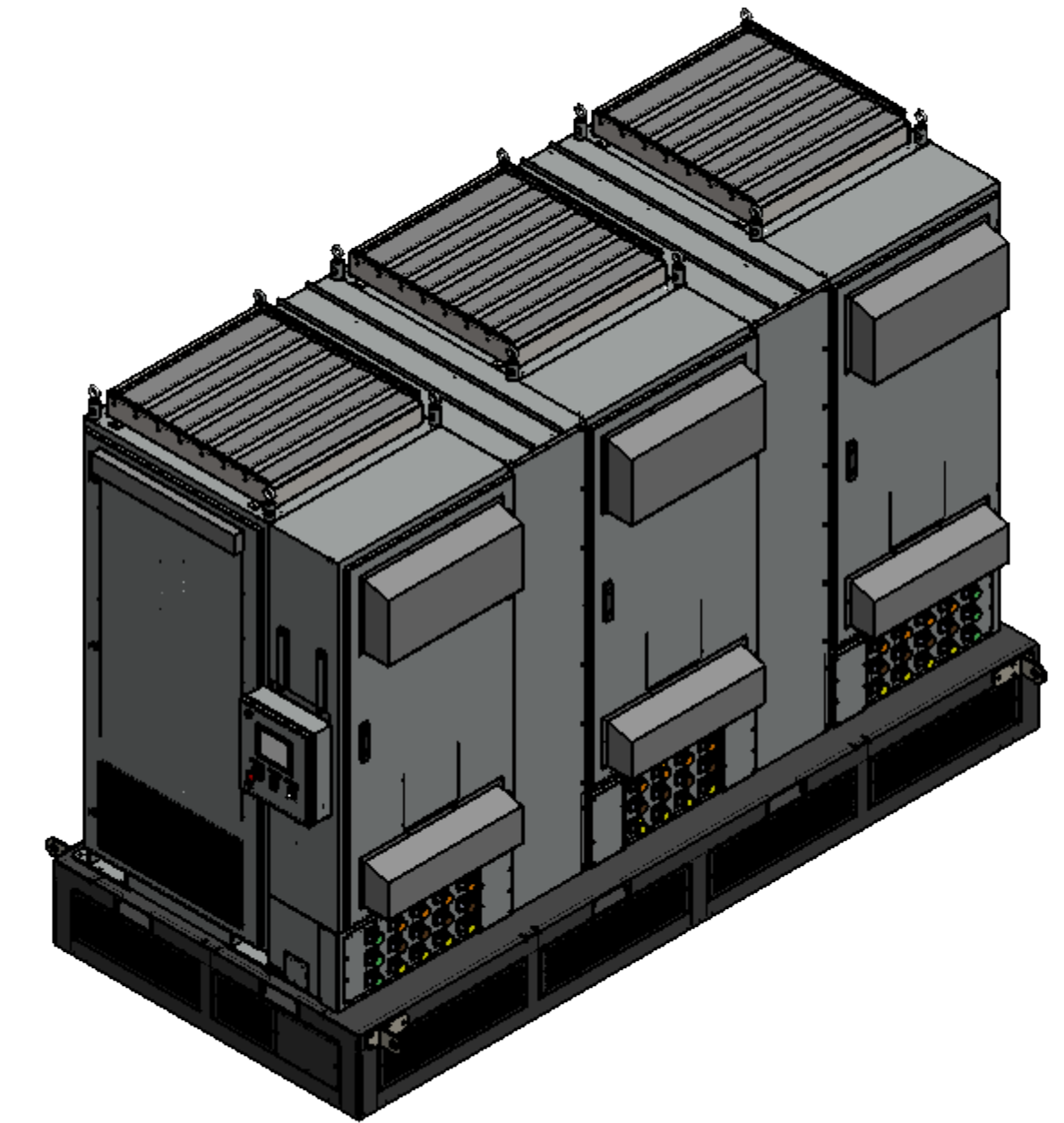

L.H.S VIEW

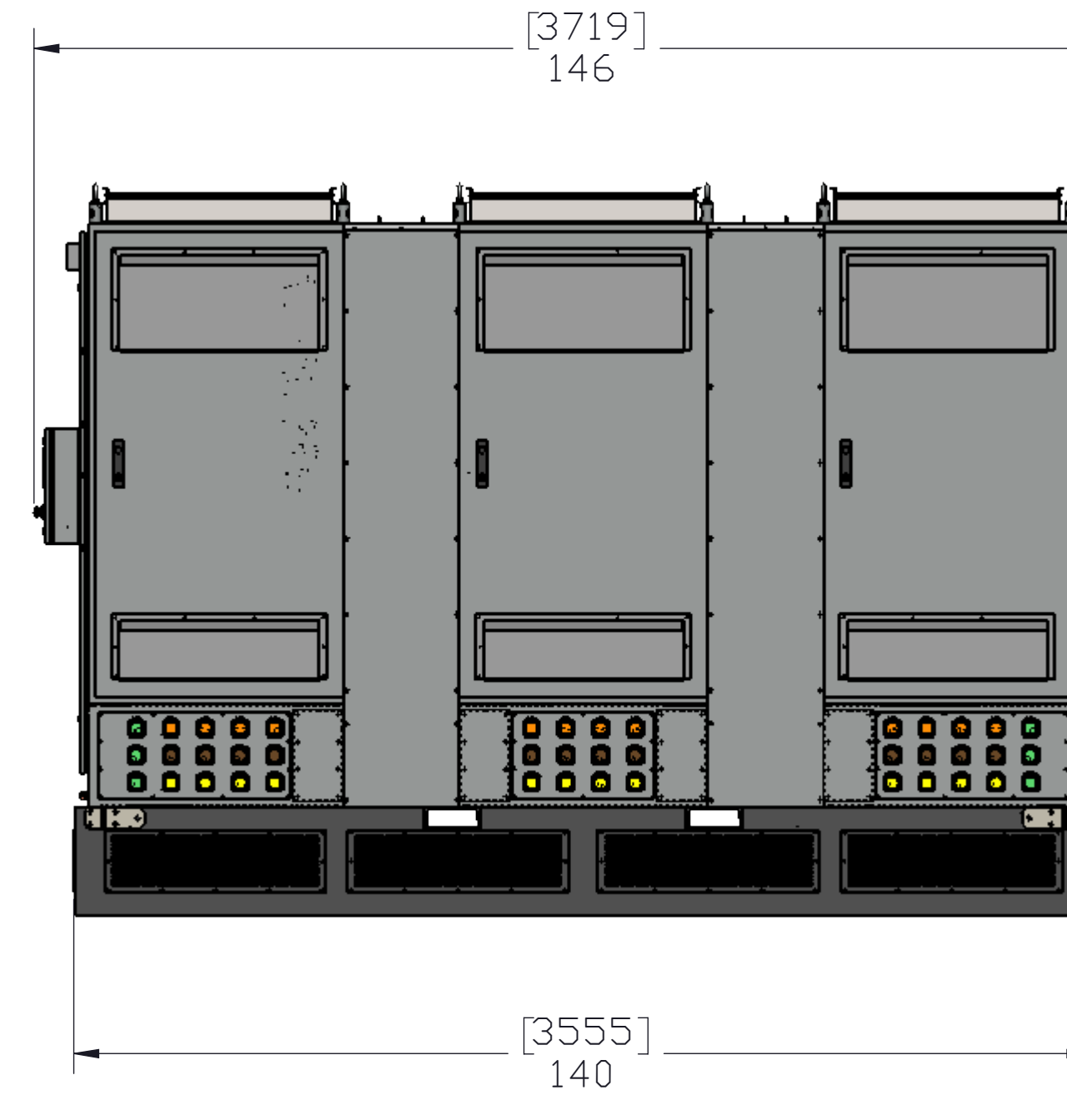

FRONT VIEW

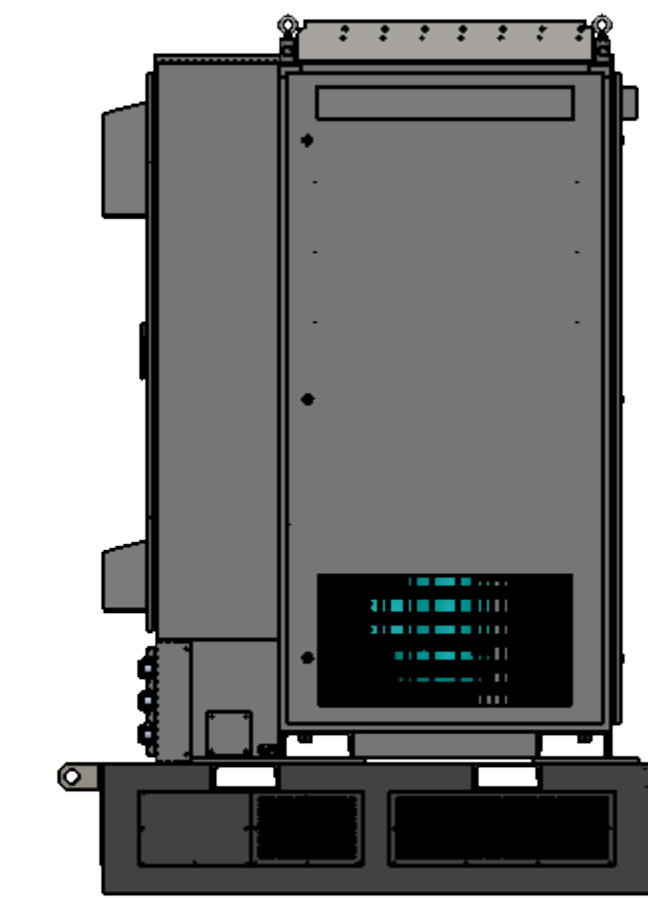

R.H.S VIEW

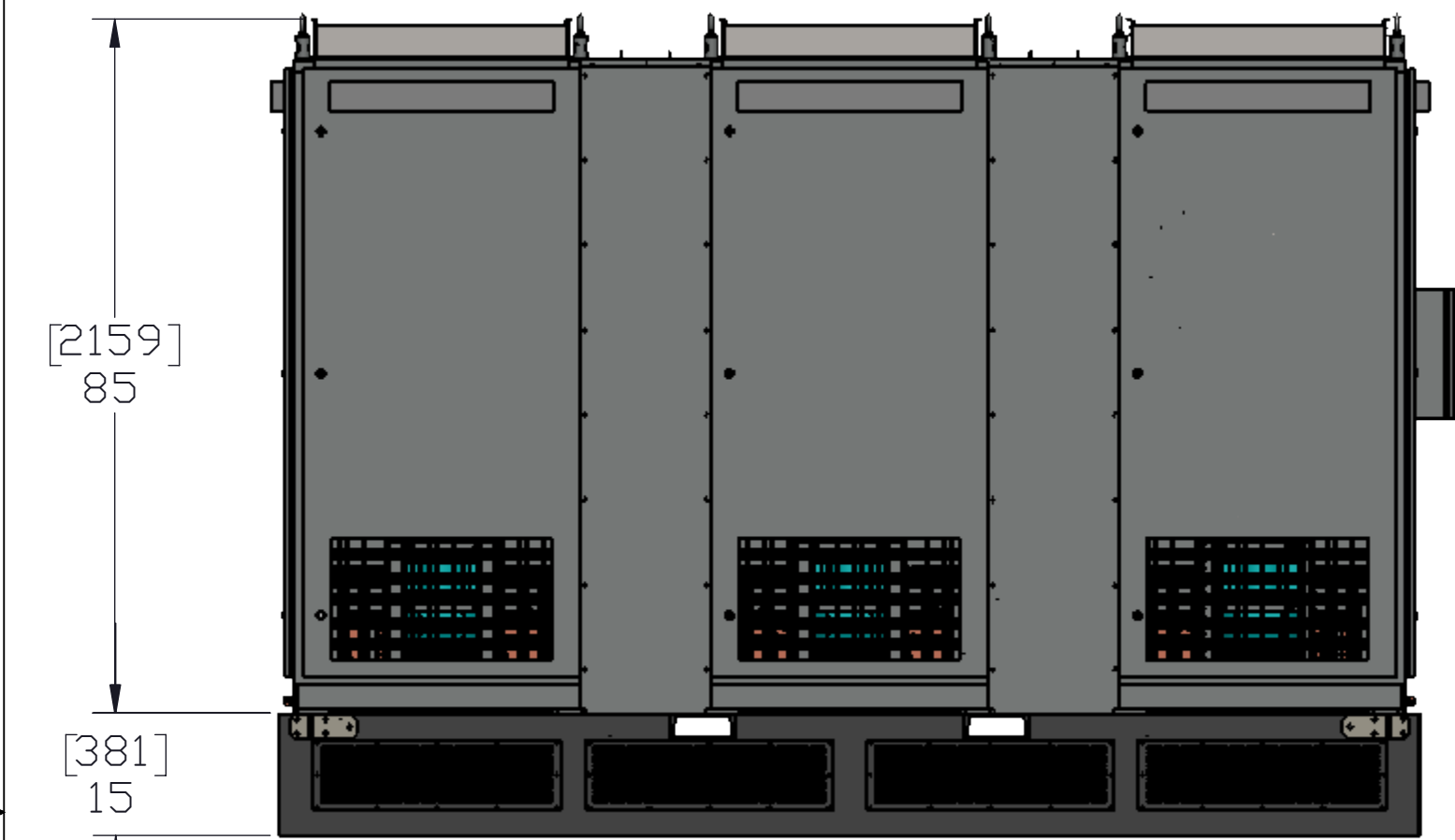

BACK VIEW

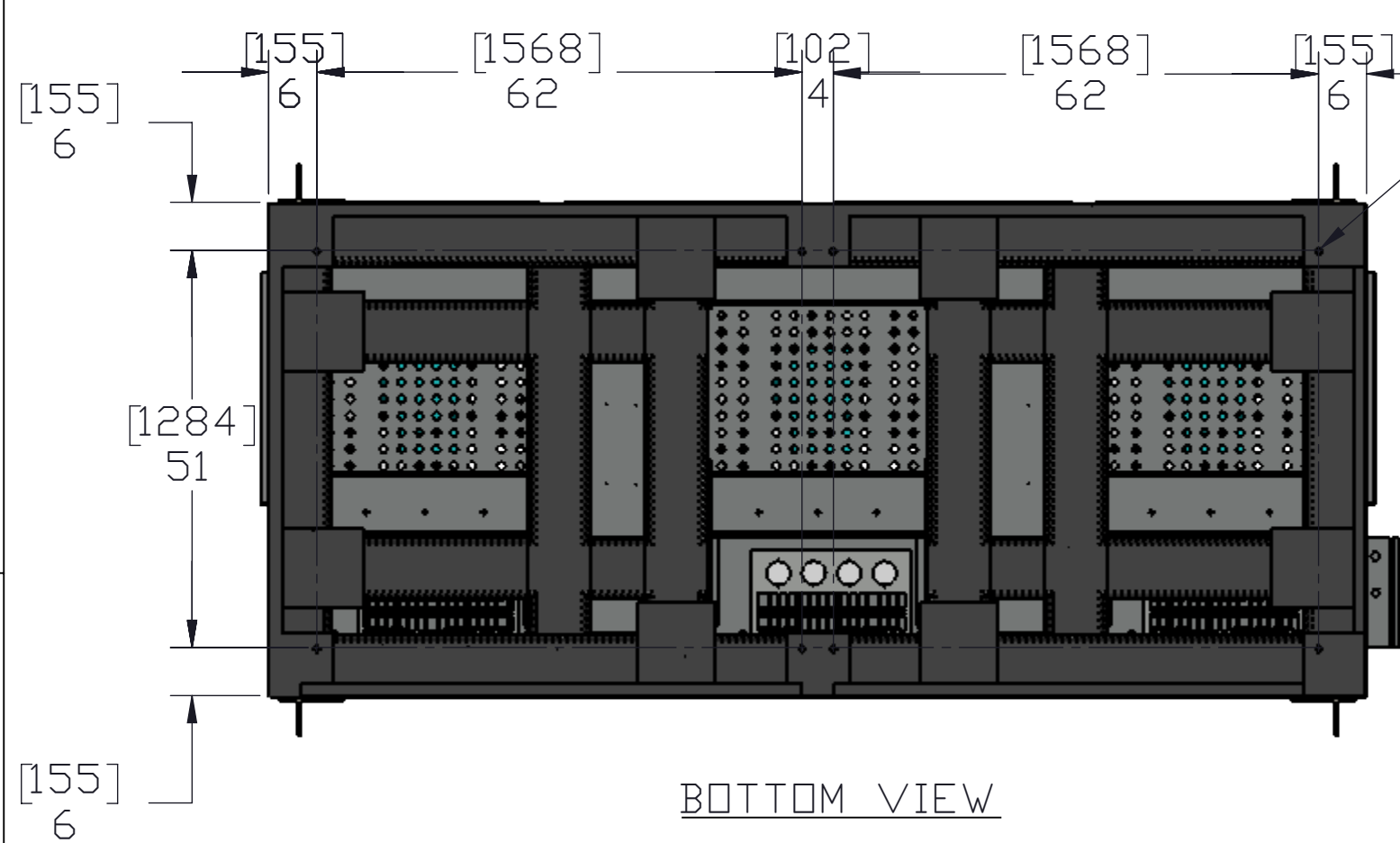

BOTTOM VIEW

DESCRIPTION:

THIS IS A MODERN LARGE CAPACITY RESISTIVE LOAD BANK SYSTEM INTENDED FOR FIELD USE IN TESTING AND MAINTENANCE EXERCISE OF GENERATORS, UPS AND OTHER AC POWER SOURCES. ULB SERIES LOAD BANKS ARE DESIGNED FOR OUTDOOR OR INDOOR INSTALLATION AVAILABLE IN 200KW-3000KW SIZES, DIGITALLY CONTROLLED VIA AN ON-BOARD PLC WITH TOUCH SCREEN DISPLAY, CAPABLE OF DATA MONITORING AND DATA ACQUISITION. CONTROL CONSOLE CAN BE MOUNTED ON THE LOAD BANK OR AT REMOTE LOCATION.

MODEL NUMBER ULB-R3000-480-DS SHOWN
 MODEL NUMBER CODE:ULB-RXXXX-VOLTAGE-OPTION

ULB - UNIVERSAL LOAD BANKS
 R - RESISTIVE
 XXXX - MAX. CAPACITY 3000 KW

VOLTAGE - NOMINAL VOLTAGE

D - OPTION: FOR OUTDOOR USE
 I - OPTION: FOR INDOOR USE
 S - OPTION: STATIONARY
 P - OPTION: PORTABLE ON CASTERS
 T - OPTION: TRAILER MOUNTED

LOAD BANK OUTLINE DRAWING

- NOTE:**
- ALL DIMENSIONS ARE IN INCHES[MM].
 - ALL DIMENSIONS ARE APPROX.
 - USE JMLU2 CATEGORY GASKET, 1-1/2" WIDE X 3/8" X THICK FOR SEALING ON ALL LARGE DOORS AND 1" WIDE X 3/8" THICK FOR CONTROL ENCLOSURE.
 - POWDER COAT USING DTV2 CATEGORY POWDER, DFT: MINIMUM 80 MICRON.

FINISH POWDER COATED RAL7042/RAL6037/ RAL5005/RAL3011/ RAL7015	MATERIAL ASSEMBLY	UNLESS OTHERWISE SPECIFIED DIMENSIONS ARE IN INCHES TOLERANCES:FRACTIONS ± 1/4 ANGLES ± 0° 30' 2 PLACE DECIMALS ± .03 3 PLACE DECIMALS ± .010
---	----------------------	--

CONFIDENTIAL/PROPRIETARY

THIS DOCUMENT CONTAINS THE CONFIDENTIAL AND PROPRIETARY INFORMATION OF ULB. YOU MAY NOT POSSESS, USE, COPY OR DISCLOSE THIS DOCUMENT OR ANY INFORMATION IN IT FOR ANY PURPOSE WITHOUT EXPRESS WRITTEN PERMISSION. NEITHER RECEIPT, FROM ANY SOURCE, NOR POSSESSION OF THIS DOCUMENT, CONSTITUTES SUCH PERMISSION. POSSESSION, USE, COPYING OR DISCLOSURE BY ANYONE WITHOUT EXPRESS WRITTEN PERMISSION OF ULB IS NOT AUTHORIZED AND MAY RESULT IN CRIMINAL AND/OR CIVIL LIABILITY.

APPROVALS		DATE
DRAWN	TRP	18/10/23
CHECKED	KP	18/10/23
ENGR.	KP	18/10/23
QUAL.		
REL.		
CONTRACT NUMBER		
JOB# 1259		
DO NOT SCALE DRAWING		

ULB UNIVERSAL LOAD BANKS

3000KW RESISTIVE LOAD BANK
 MODEL-R3000-480-DS

SIZE	CAGE CODE	
D	8LKM0	A403006-P2
SCALE	WEIGHT:	SHEET: 1